

BALUSTRADE

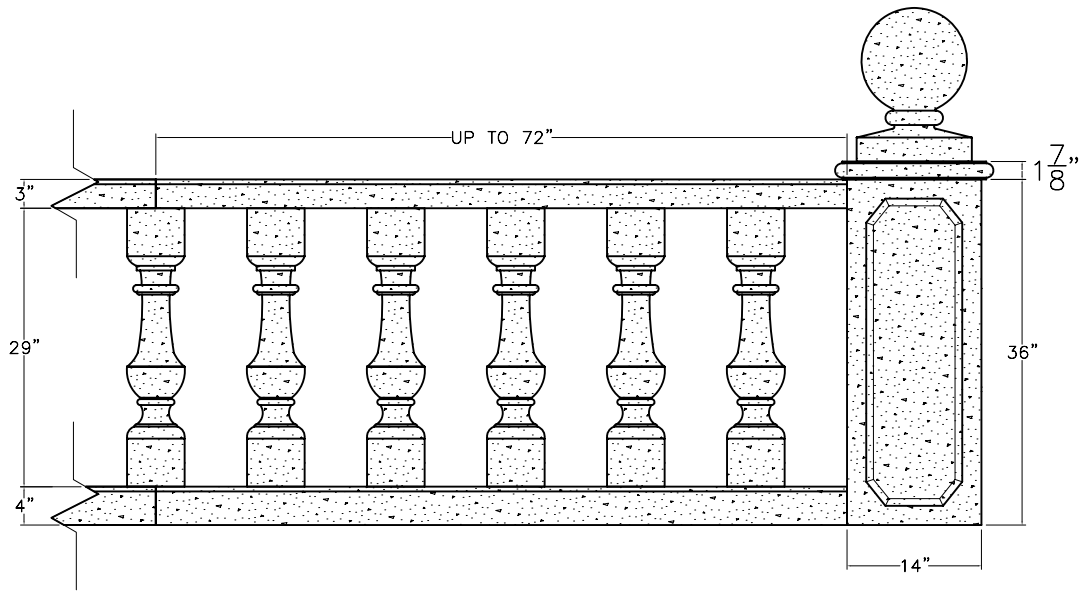

BALUSTERS

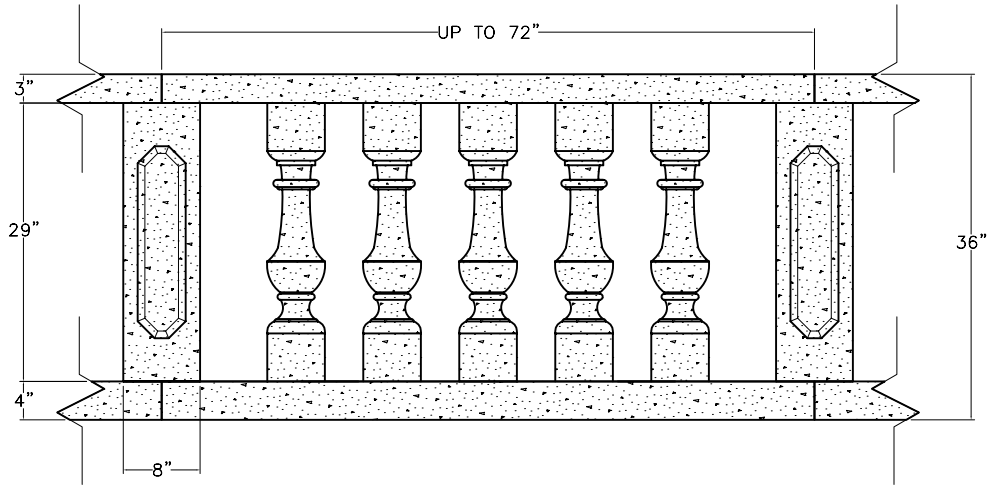
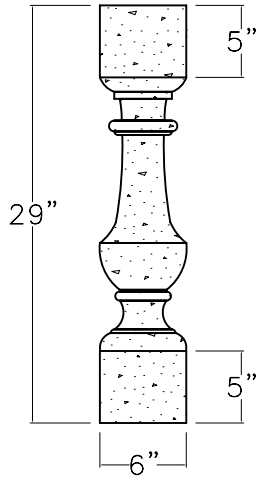

#B-1

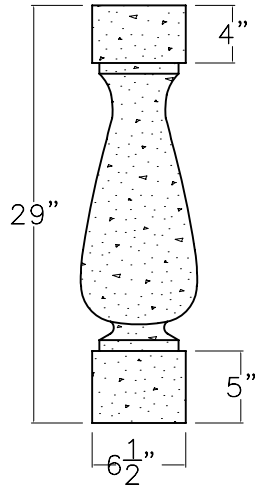

#B-2

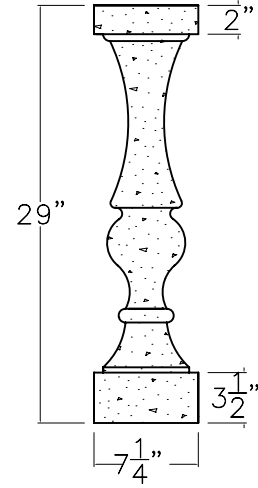

#B-3

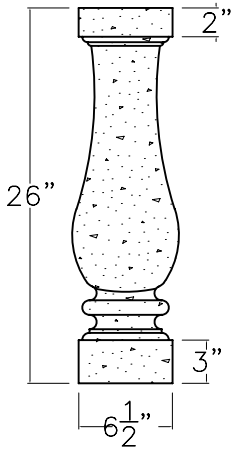

#B-4

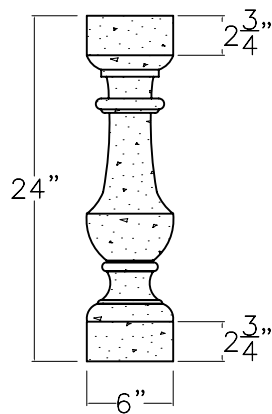

#B-5

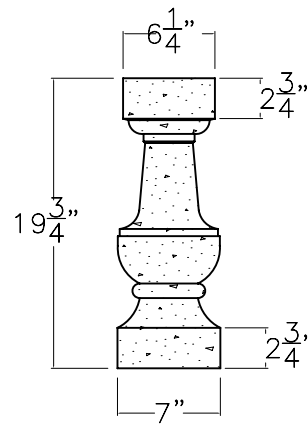

#B-6

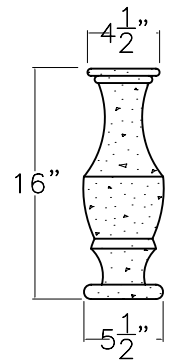

#B-7

BALUSTERS B-1 THROUGH B-5 HAVE ROUND BODIES
AND SQUARE TOPS AND BOTTOMS
B-6 IS SQUARE TOP TO BOTTOM, AND
B-7 IS ROUND TOP TO BOTTOM

BOTTOM RAILS

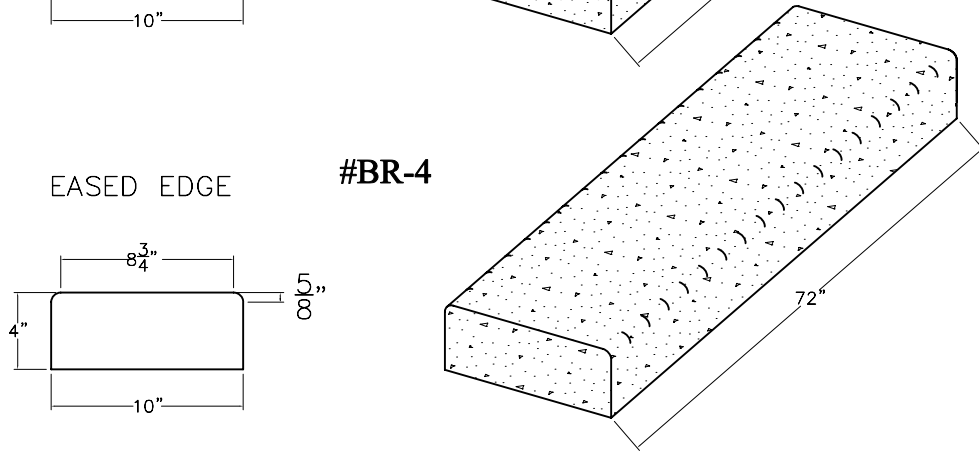
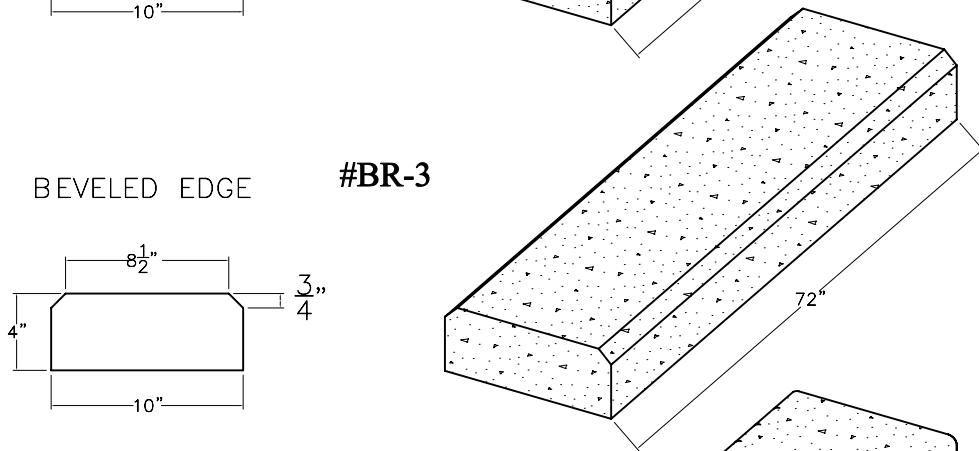
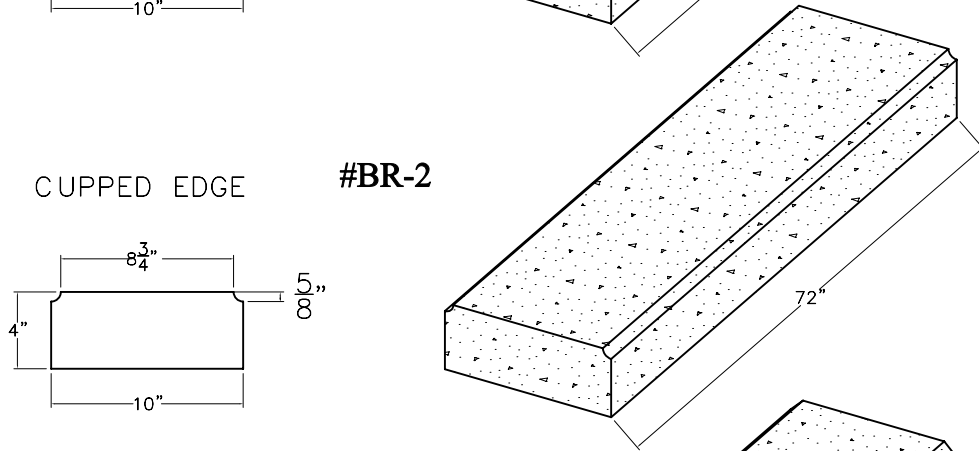
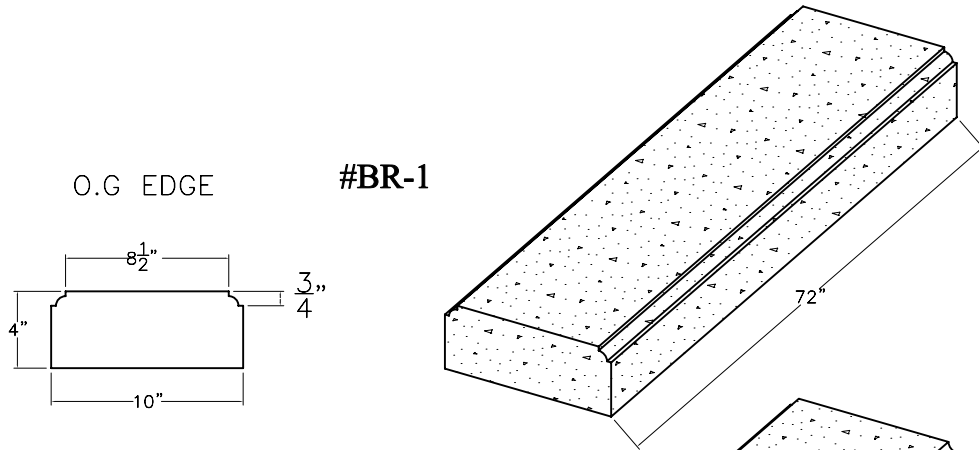

TOP RAILS

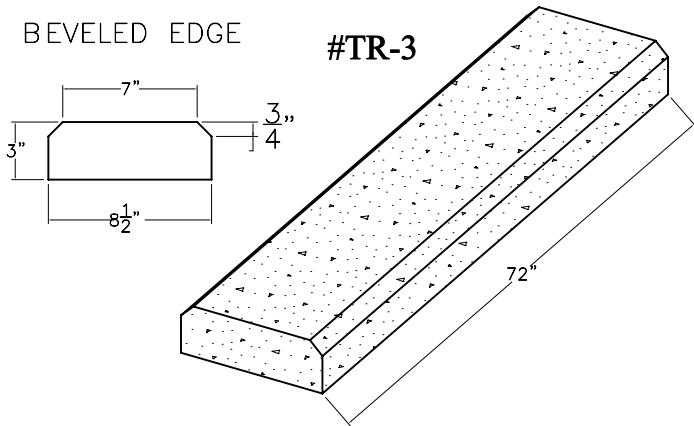
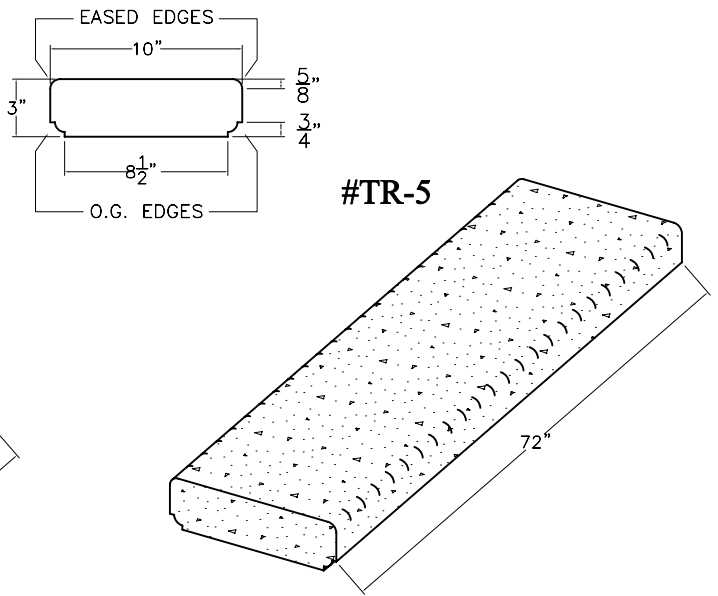
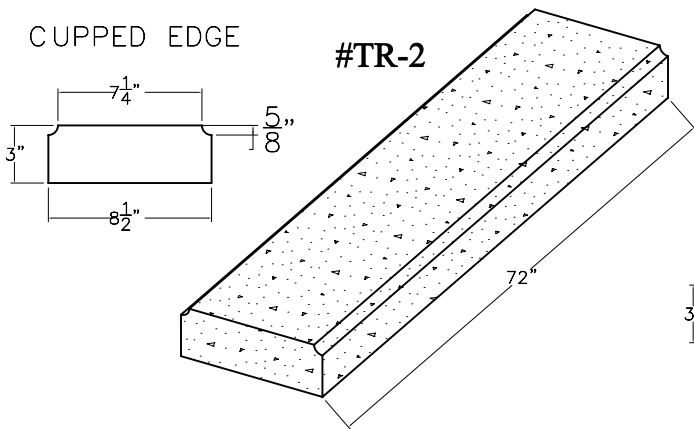
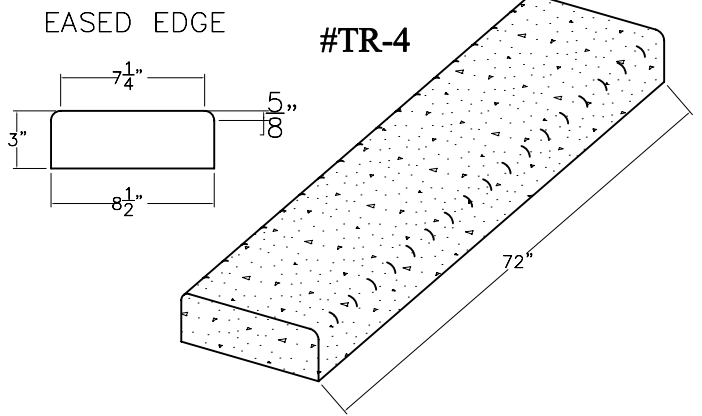
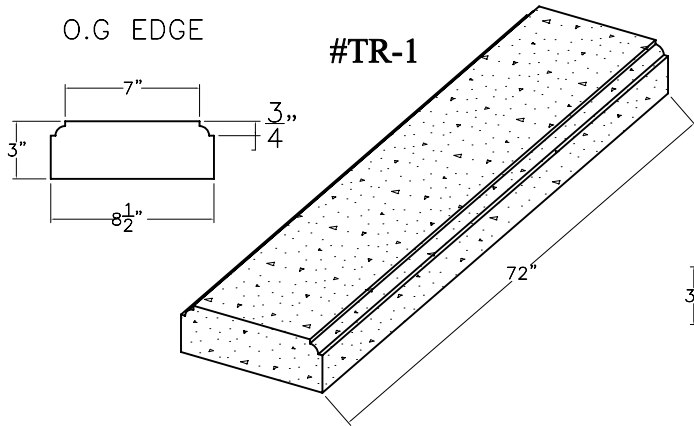

NEWEL POSTS

#NP-24

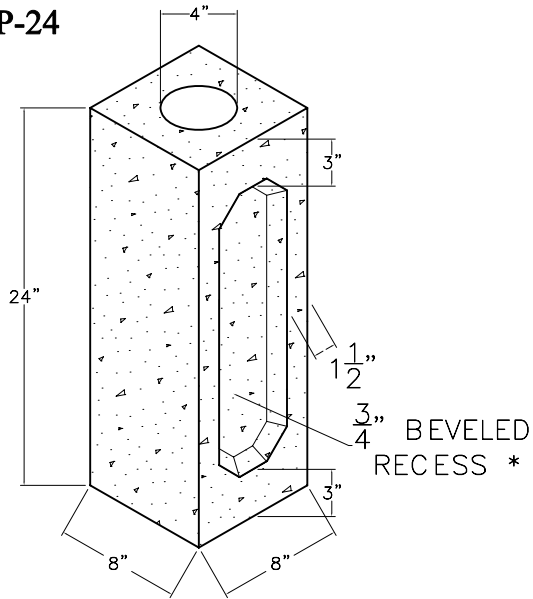

#NP-26

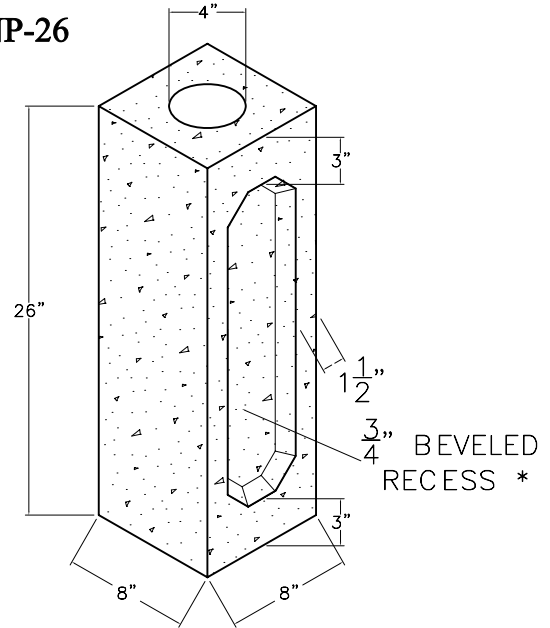

#NP-29

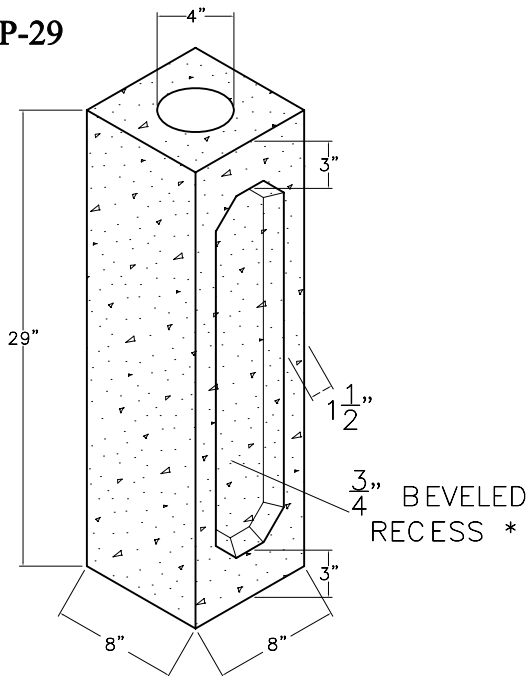

#NP-36

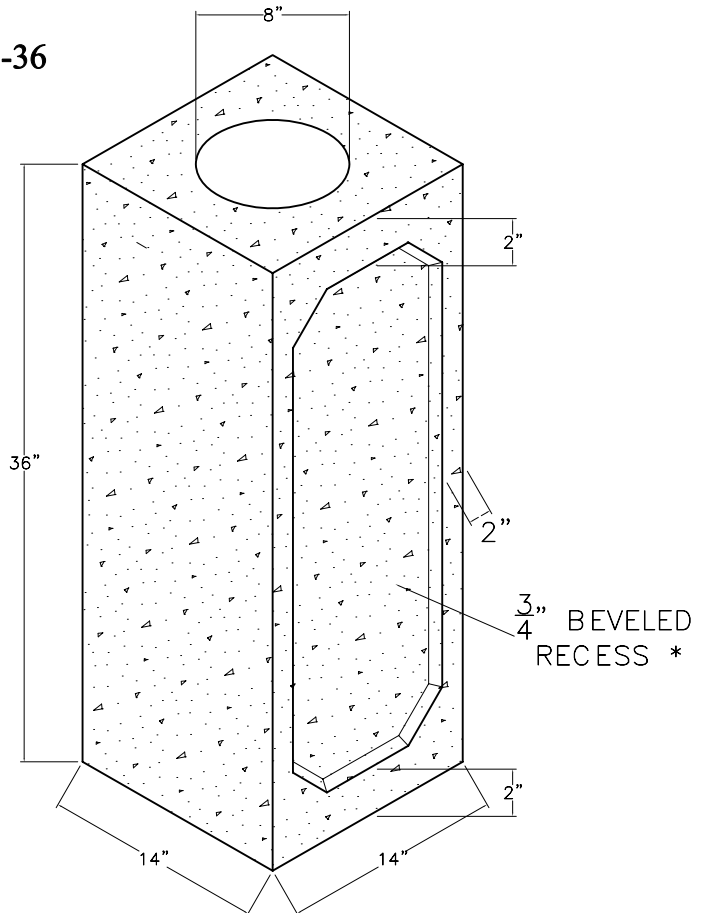

* AVAILABLE WITH RECESS ON MULTIPLE SIDES UPON REQUEST

BALL FINIALS

#BF-11a

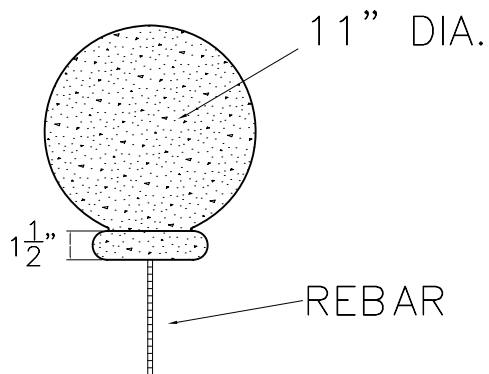

#BF-18a

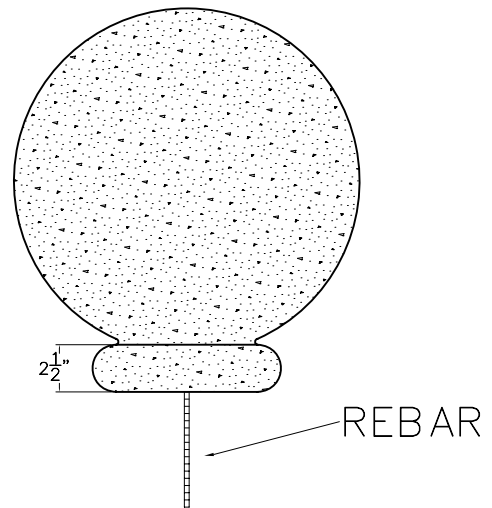

#BF-11b

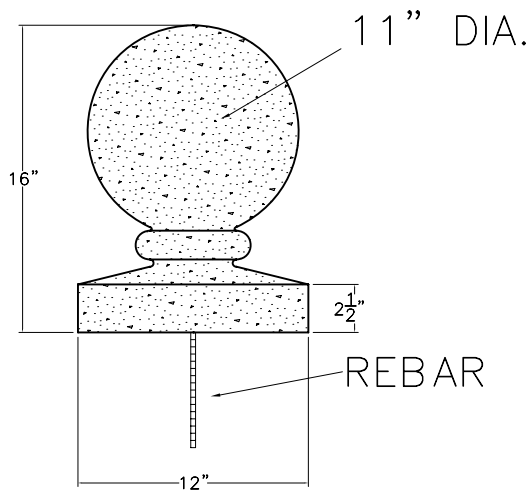

#BF-18b

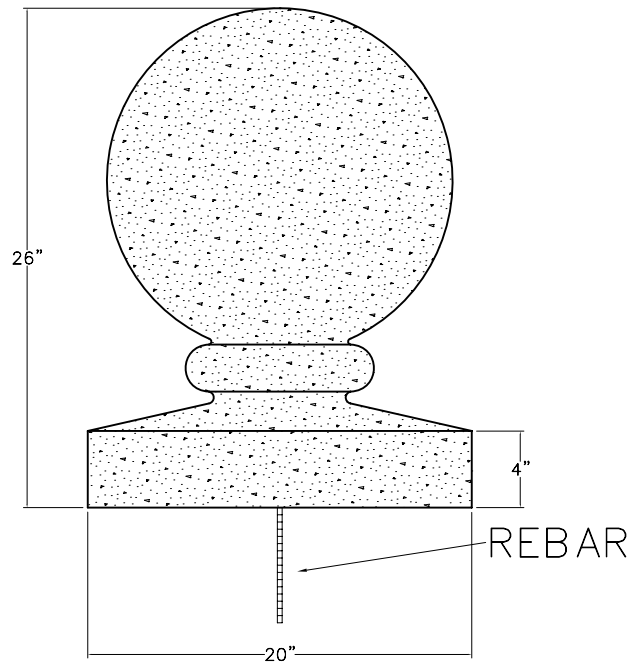

SPHERES

#S-11

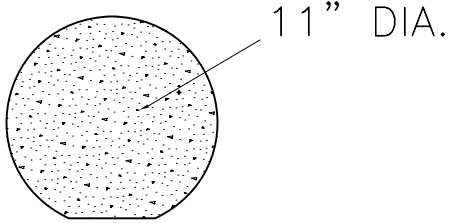

#S-24

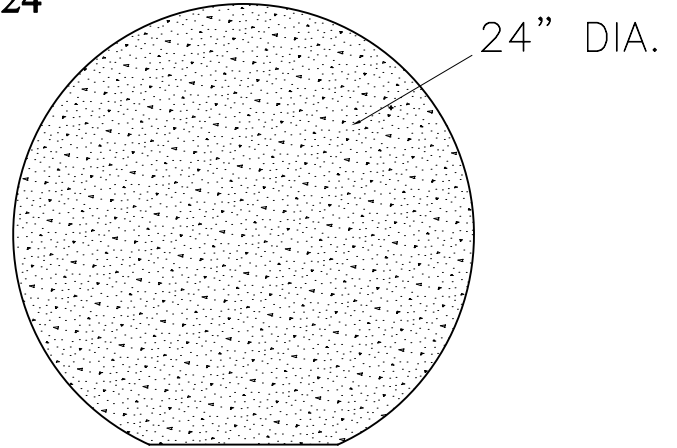

#S-18

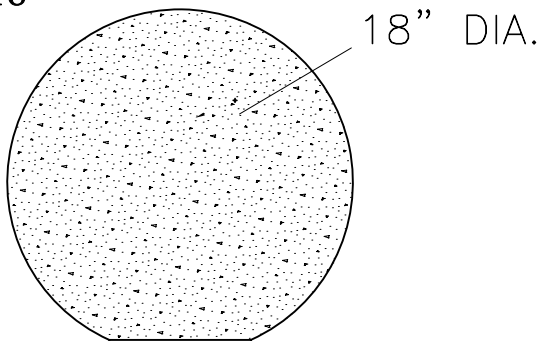

#S-36

